

LEFT SIDE VIEW  
REAR RISERS

FRONT VIEW  
REAR RISERS

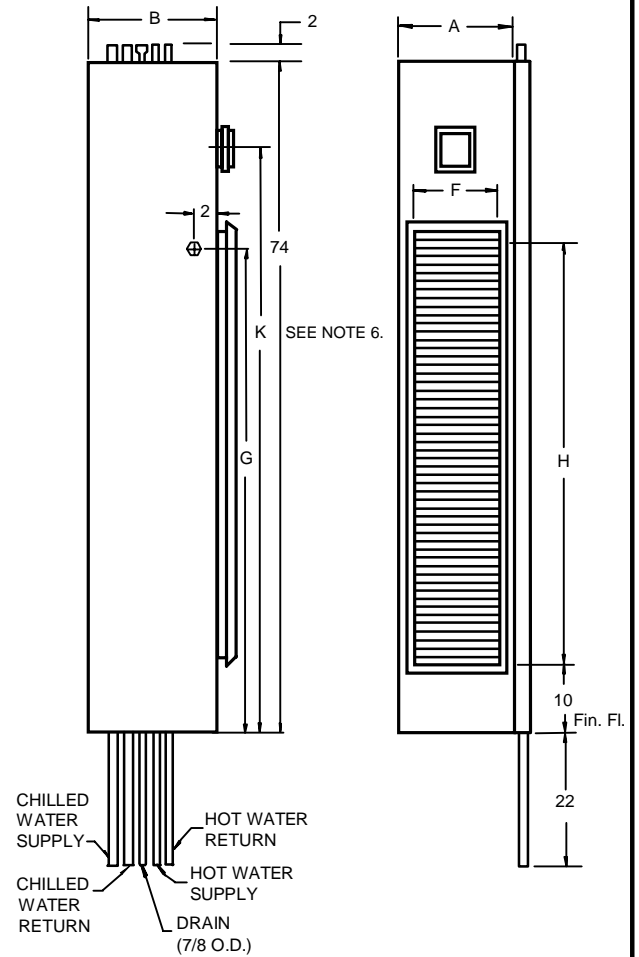

LEFT SIDE VIEW  
SIDE RISERS  
R.H. SHOWN

FRONT VIEW  
SIDE RISERS  
R.H. SHOWN

**NOTES:**

1. See drawing number 411 for top discharge dimensions. The return air grille is always on the front of the unit.
2. Cabinet is continuous galvanized steel, suitable for direct application of "drywall" plaster board.
3. Return air grille is extruded aluminum.
4. Supply, return and drain risers are type M copper, standard or type L, optional. Riser assemblies include four ball valves inside the cabinet.
5. See drawing number 409-PT for detailed riser dimensions and plan views.
6. Remote thermostat is required on units for 48" thermostat height.

UNIT MODEL	NOMINAL CFM	A	B	F	H	G	K
WF*-1000-4P	1000	24	24	20	48	51	62
WF*-1200-4P	1200	24	24	20	56	59	70

\* C = 3 ROW  
\* D = 4 ROW

All dimensions in inches.

**VERTICAL FAN-COIL UNITS**

**THE WHALEN COMPANY**

EASTON, MARYLAND

**FAN COIL UNITS - 4 PIPE  
1000 AND 1200 CFM UNITS  
WITH INTERNAL DRAIN PAN  
3 OR 4 ROW COOLING COILS**

**DRAWING NUMBER 403B-K-PT**

MARCH 1999