

LEFT SIDE VIEW  
REAR RISERS

FRONT VIEW  
REAR RISERS

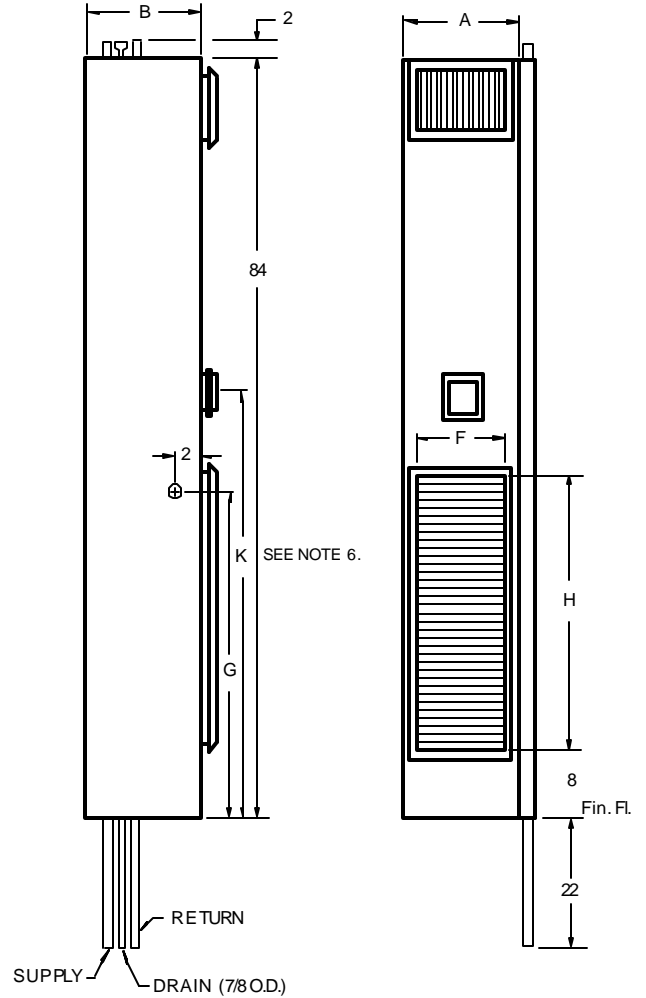

LEFT SIDE VIEW  
SIDE RISERS  
R.H. SHOWN

FRONT VIEW  
SIDE RISERS  
R.H. SHOWN

NOTES:

1. See drawing number 411 for supply grille or register options. The return air grille is always on the front of the unit.
2. Cabinet is continuous galvanized steel, suitable for direct application of "drywall" plaster board.
3. Return air grille is extruded aluminum.
4. Supply, return and drain risers are type M copper, standard or type L, optional. Riser assemblies include two ball valves inside the cabinet.
5. See drawing number 408-PT for detailed riser dimensions and plan views.
6. 48" thermostat height is standard on WF\* 300-400 units. Remote thermostat is required on WF\* 600 - 800 units for 48" thermostat height.

UNIT MODEL	NOMINAL CFM	A	B	F	H	G	K
WF*-300-##	300	16	16	14	32	34	48
WF*-400-##	400	16	16	14	36	38	48
WF*-600-##	600	18	16	14	40	41	52
WF*-800-##	800	18	16	14	44	45	56

All dimensions in inches.

\* C = 3 ROW  
 \* D = 4 ROW  
 ## = 2P, ET or AE

HI-RISE VERTICAL FAN-COIL UNITS

**THE WHALEN COMPANY**  
 EASTON, MARYLAND

FAN COIL UNITS-2 PIPE  
 AND OPTIONAL ELECTRIC HEAT  
 3 OR 4 ROW COOLING COILS  
 WITH INTERNAL DRAIN PAN

DRAWING NUMBER 401C-PT

FEBRUARY 2002