

LEFT SIDE VIEW
REAR RISERS

FRONT VIEW
REAR RISERS

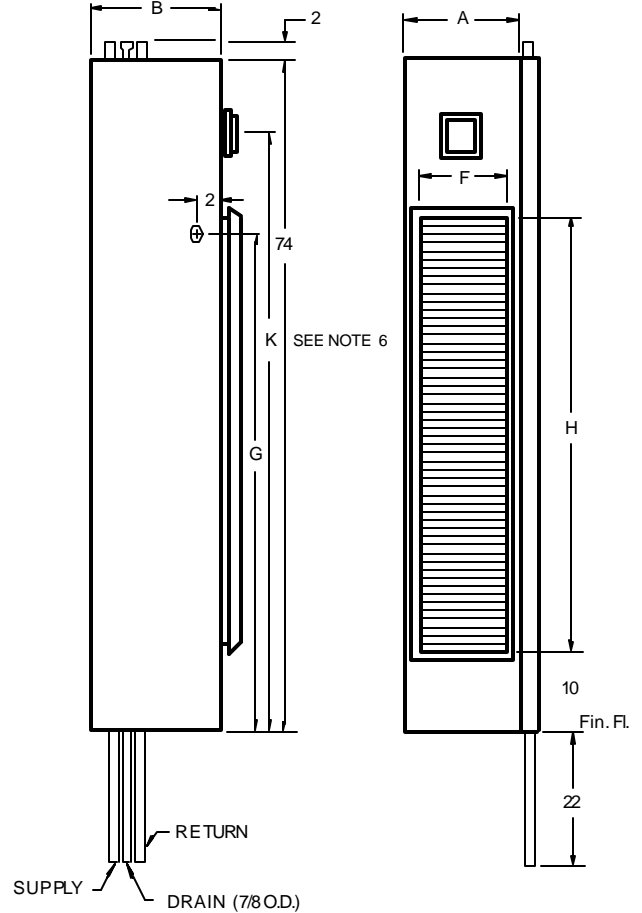

LEFT SIDE VIEW
SIDE RISERS
R.H. SHOWN

FRONT VIEW
SIDE RISERS
R.H. SHOWN

NOTES:

1. See drawing number 411 for top discharge dimensions. The return air grille is always on the front of the unit.
2. Cabinet is continuous galvanized steel, suitable for direct application of "drywall" plaster board.
3. Return air grille is extruded aluminum.
4. Supply, return and drain risers are type M copper, standard or type L, optional. Riser assemblies include two ball valves inside the cabinet.
5. See drawing number 408-PT for detailed riser dimensions and plan views.
6. Remote thermostat is required on units for 48" thermostat height.

UNIT MODEL	NOMINAL CFM	A	B	F	H	G	K
WF*-1000-##	1000	24	24	20	48	51	62
WF*-1200-##	1200	24	24	20	56	59	70

* C = 3 ROW
 * D = 4 ROW
 ## = 2P, ET or AE

All dimensions in inches.

HI-RISE VERTICAL FAN-COIL UNITS

THE WHALEN COMPANY
 EASTON, MARYLAND

FAN COIL UNITS - 2 PIPE AND
 OPTIONAL ELECTRIC HEAT - 1000
 AND 1200 CFM UNITS WITH INTERNAL
 DRAIN PAN - 3 OR 4 ROW COOLING COILS

DRAWING NUMBER 401C-K-PT
 FEBRUARY 2002