

LEFT SIDE VIEW

FRONT VIEW

L.H. SHOWN

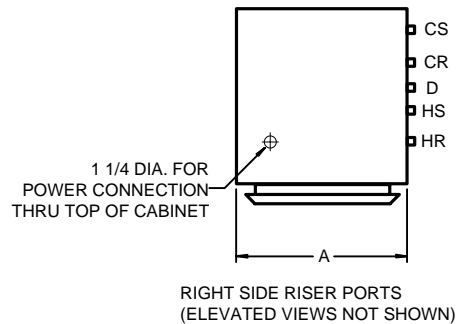

RIGHT SIDE RISER PORTS (ELEVATED VIEWS NOT SHOWN)

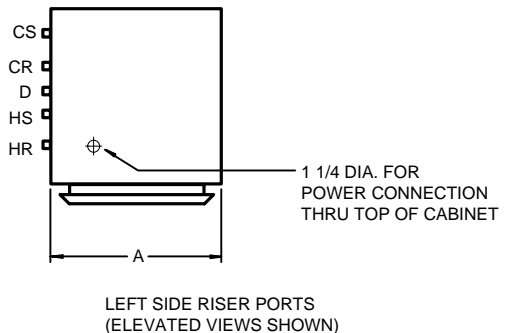

LEFT SIDE RISER PORTS (ELEVATED VIEWS SHOWN)

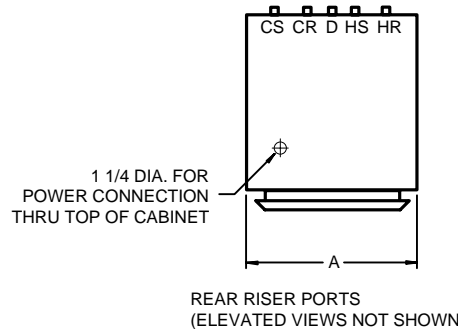

REAR RISER PORTS (ELEVATED VIEWS NOT SHOWN)

PLAN VIEW

NOTES:

1. See drawing number 411 for supply grille or register options.
2. Cabinet is continuous galvanized steel, suitable for direct application of "drywall" plaster board.
3. Return air grille is clear anodized aluminum.
4. Coil piping includes (4) ball shutoff valves with 5/8" nipples for connection to field piping. Nipples extend 1" nom. thru ports on rear or side of cabinet.
5. 48" thermostat height is standard of WF\*-300 units. Remote thermostat is required on WF\*400-800 units for 48" thermostat height.

UNIT MODEL	NOMINAL CFM	A	B	F	H	G	K	M
WFC-300-4P	300	16	18	14	36	38	48	26
WFC-400-4P	400	16	18	14	40	42	52	29
WFC-600-4P	600	18	18	14	44	45	56	32
WFC-800-4P	800	18	18	14	48	49	60	36

All dimensions in inches.

HI-RISE VERTICAL FAN-COIL UNITS

**THE WHALEN COMPANY**  
EASTON, MARYLAND

WFC 4-PIPE UNITS WITH VALVE CONTROL AND INTERNAL DRAIN PAN (RISERS BY OTHERS)

DRAWING NUMBER 413D-PT-NR

FEBRUARY 2008