

LEFT SIDE VIEW  
REAR RISERS

FRONT VIEW  
REAR RISERS

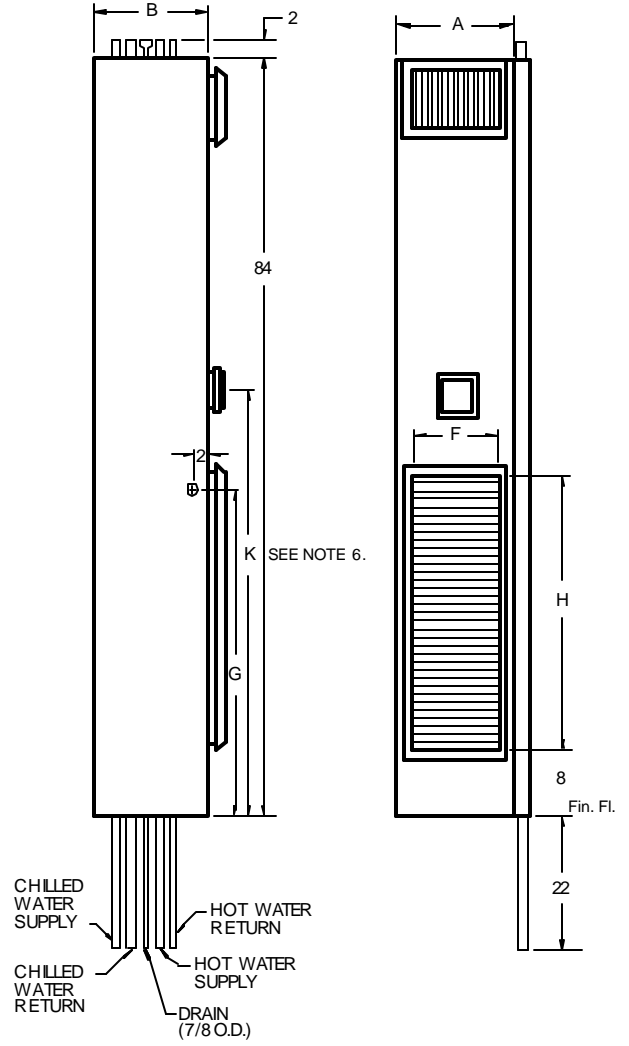

LEFT SIDE VIEW  
SIDE RISERS  
R.H. SHOWN

FRONT VIEW  
SIDE RISERS  
R.H. SHOWN

NOTES:

1. See drawing number 411 for supply grille or register options. The return air grille is always on the front of the unit.
2. Cabinet is continuous galvanized steel, suitable for direct application of "drywall" plaster board.
3. Return air grille is clear anodized aluminum.
4. Supply, return and drain risers are type M copper, standard or type L, optional. Riser assemblies include four ball valves inside the cabinet.
5. See drawing number 409-PT for detailed riser dimensions and plan views.
6. 48" thermostat height is standard on WF\* 300 units. Remote thermostat is required on WF\* 400 - 800 units for 48" thermostat height.

UNIT MODEL	NOMINAL CFM	A	B	F	H	G	K
WF*-300-4P	300	16	18	14	36	38	48
WF*-400-4P	400	16	18	14	40	42	52
WF*-600-4P	600	18	18	14	44	45	56
WF*-800-4P	800	18	18	14	48	49	60

\* C = 3 ROW  
\* D = 4 ROW

All dimensions in inches.

VERTICAL FAN-COIL UNITS

THE WHALEN COMPANY

EASTON, MARYLAND

FAN COIL UNITS-4 PIPE  
WITH INTERNAL DRAIN PAN  
3 OR 4 ROW COOLING COILS

DRAWING NUMBER 403C-PT

JANUARY 2002