

**LEFT SIDE VIEW
REAR RISERS**

**FRONT VIEW
REAR RISERS**

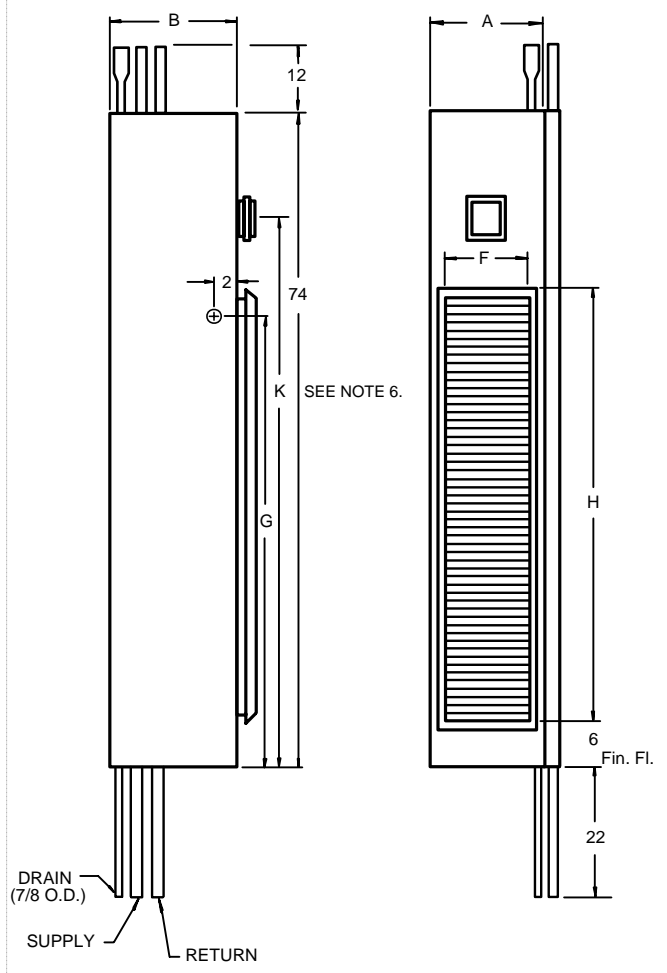

**LEFT SIDE VIEW
SIDE RISERS
R.H. SHOWN**

**FRONT VIEW
SIDE RISERS
R.H. SHOWN**

NOTES:

1. See drawing number 411 for top discharge dimensions . The return air grille is always on the front of the unit.
2. Cabinet is continuous galvanized steel, suitable for direct application of "drywall" plaster board.
3. Return air grille is extruded aluminum.
4. Supply, return and drain risers are type M copper, standard or type L, optional. Riser assemblies include two ball valves inside the cabinet.
5. See drawing number 408 for detailed riser dimensions and plan views.
6. Remote thermostat is required on units for 48" thermostat height.

UNIT MODEL	NOMINAL CFM	A	B	F	H	G	K
WF*-1000-##	1000	24	24	20	48	47	58
WF*-1200-##	1200	24	24	20	56	55	66

* C = 3 ROW
 * D = 4 ROW
 ## = 2P, ET or AE

All dimensions in inches.

VERTICAL FAN-COIL UNITS

THE WHALEN COMPANY
 EASTON, MARYLAND

**FAN COIL UNITS - 2 PIPE
 AND OPTIONAL ELECTRIC HEAT
 1000 AND 1200 CFM UNITS
 3 OR 4 ROW COOLING COILS**

DRAWING NUMBER 401D-K

MARCH 2008