

**LEFT SIDE VIEW
REAR RISERS**

**FRONT VIEW
REAR RISERS**

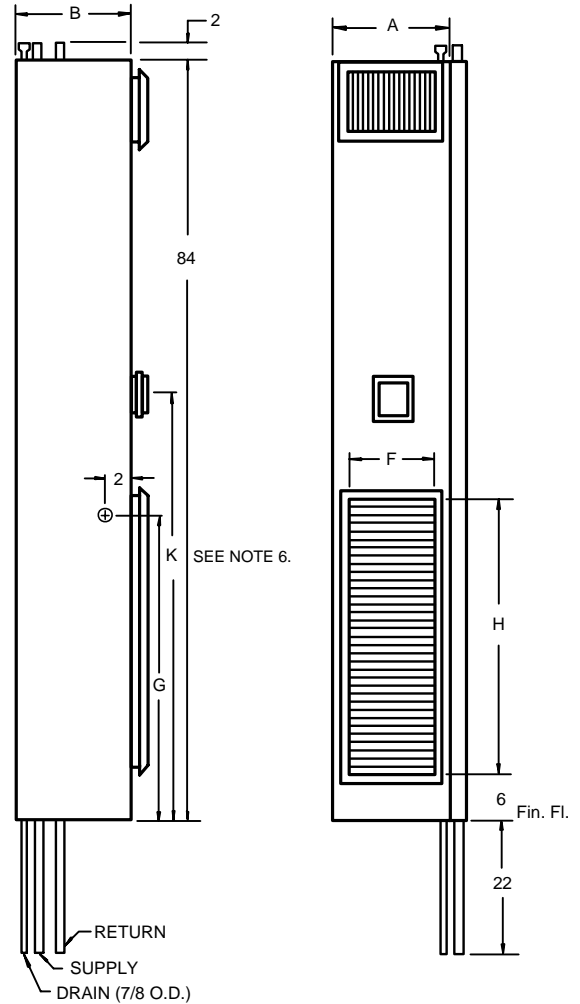

**LEFT SIDE VIEW
SIDE RISERS
R.H. SHOWN**

**FRONT VIEW
SIDE RISERS
R.H. SHOWN**

NOTES:

1. See drawing number 411 for supply grille or register options. The return air grille is always on the front of the unit.
2. Cabinet is continuous galvanized steel, suitable for direct application of "drywall" plaster board.
3. Return air grille is clear anodized aluminum.
4. Supply, return and drain risers are type M copper, standard or type L, optional. Riser assemblies include two ball valves inside the cabinet.
5. See drawing number 408 for detailed riser dimensions and plan views.
6. 48" thermostat height is standard on WF* 300- 600 units. Remote thermostat is required on WF*-800 for 48" thermostat height.

UNIT MODEL	NOMINAL CFM	A	B	F	H	G	K
WF*-300-##	300	18	16	14	30	30	48
WF*-400-##	400	18	16	14	34	34	48
WF*-600-##	600	18	16	14	38	37	48
WF*-800-##	800	18	16	14	42	41	52

All dimensions in inches.
 * C = 3 ROW
 * D = 4 ROW
 ## = 2P, ET or AE

NOTE SPECIAL 18" CABINET WIDTH ON 300 & 400 CFM UNITS

VERTICAL FAN-COIL UNITS

THE WHALEN COMPANY
 EASTON, MARYLAND

**FAN COIL UNITS-2 PIPE AND OPTIONAL ELECTRIC
 HEAT - 3 OR 4 ROW COOLING COILS
 w/ ECM FAN MOTORS**

 DRAWING NUMBER 401C-ECM