

LEFT SIDE VIEW

FRONT VIEW

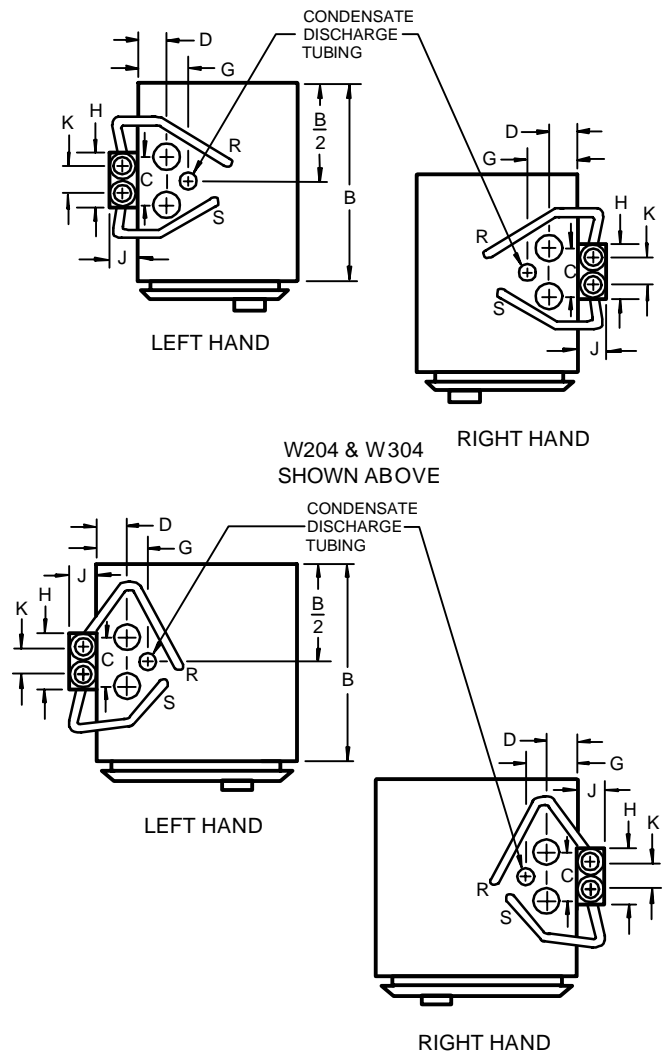

W204 & W304 SHOWN ABOVE
W304X, W404, W504, W604 & W804 SHOWN ABOVE

PLAN VIEW

NOTES:

1. See drawing number 111 for supply grille or register options. The return air grille is always on the front of the unit.
2. Cabinet is continuous galvanized steel, suitable for direct application of "drywall" plaster board.
3. Return air grille is extruded aluminum.
4. Supply, return and drain risers are copper.
5. Two ball type hot water shut off valves are factory installed inside the cabinet. Standard hot water control valve is electric two way, two position type.
6. Fan motor is 115 volt, 60 cycle, single phase.
7. Unless otherwise noted, the fan motor runs continuously on either high or low speed.
8. Hot water risers are centered on the side of each unit, and include 3/8" insulation for full length of cabinet.
9. Separate 115/1/60 field power connection to condensate pump is required at the time unit power connection is made.

UNIT MODEL	NOM CFM	A	B	C	D	E	F	G	P	T	MINIMUM SLEEVE SIZE
W204	200	12	14	2 1/2	1 1/2	2	8	2 3/4	2 1/2	3	8 X 8
W304	300	12	14	2 1/2	1 1/2	2	8	2 3/4	2 1/2	3	8 X 8
W304X	300	14	14	4	2 3/4	2	10	4 1/2	3	4	8 X 10
W404	400	16	16	4	2 3/4	3	10	4 1/2	3	4	8 X 10
W504	500	16	16	4	2 3/4	3	10	4 1/2	3	4	8 X 10
W604	600	18	16	4	2 3/4	3	12	4 1/2	3	6	8 X 10
W804	800	18	16	4	2 3/4	3	12	4 1/2	3	6	8 X 10

All dimensions in inches.

H.W. RISER SIZE	H	J	K
3/4	3 1/8	1 1/2	1 5/8
1	3 11/16	1 13/16	1 13/16
1 1/4	4 3/16	2 1/16	2 1/16
1 1/2	4 11/16	2 5/16	2 5/16

RISER HEAT-EXCHANGER VERTICAL FAN-COIL UNITS

THE WHALEN COMPANY
EASTON, MARYLAND

4-PIPE HEATING/COOLING UNITS
(WITH HOT WATER RISERS)
AND CONDENSATE PUMP

DRAWING NUMBER 107A-CP